

Please read and save this Repair Parts Manual. Read this manual and the General Operating Instructions carefully before attempting to assemble, install, operate or maintain the product described. Protect yourself and others by observing all safety information. The Safety Instructions are contained in the General Operating Instructions. Failure to comply with the safety instructions accompanying this product could result in personal injury and/or property damage! Retain instructions for future reference. AMT reserves the right to discontinue any model or change specifications at any time without incurring any obligation.

©2006 American Machine & Tool Co., Inc. of PA, A Subsidiary of The Gorman-Rupp Company, All Rights Reserved.

▲WARNING

Periodic maintenance and inspection is required on all pumps to insure proper operation. Unit must be clear of debris and sediment. Inspect for leaks and loose bolts. Failure to do so voids warranty.

Piston Drum Pumps

Nylon and Polypropylene Models

Description

These thermoplastic hand pumps are double-action piston pumps which deliver up to 17 gallons per 100 strokes. The pumps are self-priming and are built for everyday pumping at farms, construction sites and manufacturing plants.

Polypropylene pump (Model 4660-99) has excellent resistance to many organic acids, plating solutions, alcohols, and most water soluble inorganic chemicals.

Nylon pump (Model 4661-99) has excellent resistance to many lubricants, oils, detergents, and aromatic materials.

IMPORTANT: Always refer to a chemical resistance chart to confirm compatibility. Not rated for food products.

Specifications

	Model 4661-99	Model 4660-99
Type	Piston	Piston
Flow	17 Gallons per 100 strokes	17 Gallons per 100 strokes
Mounting	2" Bung adapter	2" Bung adapter
Inlet	1" NPT	1" NPT
Outlet	3/4" NPT	3/4" NPT
Hose	8 Ft. Nylon	8 Ft. Polyethylene
Spout	Nylon	Polypropylene
Nozzle	Nylon	Polypropylene
Pump housing	Nylon	Polypropylene
Piston	Nylon/Viton/Teflon	Polypropylene/Viton/Teflon
Piston rod	316 Stainless Steel	316 Stainless Steel
Valves	Nylon/Viton	Polypropylene/Viton
Vacuum breaker	Viton	Viton
Cover plate	Nylon	Polypropylene
Fastener (external)	18-8 Stainless Steel	18-8 Stainless Steel
Max. Temp. (Water)	130° F (77° C)	130° F (77° C)
Ph range	7 to 9	4 to 11
Suction tube	3-piece Nylon (std.)	3-piece Polypropylene (std.)
Gasket	Cork/Nitrile	Cork/Nitrile

General Safety Information

- When using a hand pump (especially when pumping flammable, combustible or hazardous liquids) follow all electrical and safety codes as well as the United States Occupational Safety and Health Act (OSHA), most recent National Electrical Code (NEC), National Fire Protection Association, Inc.* (NFPA) Code 30 (Flammable and Combustible Code), NFPA 56A (Standard for use of Inhalation Anesthetics), NFPA 77 (Static Electricity), NFPA 78 (Lighting Protection Code), NFPA 80 (Standard for Fire Doors and Windows), NFPA 251 (Standard Methods of Fire Test of Building Construction), NFPA 704 (Identification of the Fire Hazards of Materials), other NFPA codes, local codes and ordinances, as needed in a particular application.
- Know the pump application, limitations, and potential hazards. The "WARNING" statements indicate potentially hazardous conditions for the operator or equipment. TAKE NECESSARY STEPS TO PROTECT PERSONNEL AND EQUIPMENT. Pump should only be used with liquids compatible with pump component materials. Consult PUMP CHEMICAL COMPATIBILITY CHART and PUMP SPECIFICATIONS. Also, the chemical supplier should be consulted regarding any questions of chemical compatibility, proper and safe use and handling of chemical. Misapplication of pump or use of non-compatible liquids will void warranty.

General Safety Information (Continued)

▲ WARNING *In order to properly use this product, familiarize yourself with this pump and also with the liquid (chemical, etc.) that is going to be pumped thru the unit. Although this pump is suitable for many liquids, it is not suitable for all liquids!*

3. Pumping hazardous, flammable, or combustible liquids should only be done in buildings, rooms, or areas suited for this purpose. (See NFPA 30, NFPA 78, NFPA 80, NFPA 251, NFPA 704, other suitable NFPA codes, OSHA, insurance companies, local codes and ordinances).

▲ WARNING *When filling cans, drums, etc. with combustible or flammable liquids, both container pumping from and container pumping to should be bonded and grounded to dissipate possible accumulations of static electricity and minimize sparks caused by static electricity (refer to NFPA 77 for specifics and further details). Removal of outer garments in work areas where there may be flammable or explosive liquids, which are ignitable with low electrical energy, can be fatal and/or cause property damage (refer to NFPA 56A and NFPA 77 for further details).*

4. The "WARNING" and instructions for gasoline below pertain not only to gasoline, but to any flammable combustible or hazardous fluid.

▲ WARNING *Gasoline is a highly flammable fuel. The improper use, handling, or storage of gasoline can be dangerous. Prevent accidents by following these safety rules:*

- a. Use gasoline only as fuel, never as a cleaning fluid.
- b. Use only an approved container to hold or store gasoline. Never store gasoline in familiar containers such as

milk containers or soda pop bottles.

- c. Store gasoline in a cool location, out of the reach of children. Never store gasoline near heat or an open flame.
 - d. Provide a fire extinguisher nearby when working with gasoline. Be sure extinguisher is in operating condition - check the pressure gauge or indicator. Be familiar with its proper use. Consult local fire department for a correct type of extinguisher for your application. Extinguishers rated ABC by the National Fire Protection Association are appropriate for most applications.
 - e. Provide positive shut-off valves on all permanent fuel supplies. Fuel lines must be of steel piping, adequately secured, and free from leaks.
 - f. Provide adequate ventilation and clean up any spills when handling or pumping flammable liquids.
 - g. **POSITIVELY NO SMOKING!**
5. Do not use torches or apply fire or flame to this pump for any reason.
 6. Secure the discharge line before starting the pump. An unsecured discharge line will slip, possibly causing personal injury and/or property damage.
 7. Do not over-tighten nonmetallic threaded fittings. One full turn past hand tight is usually enough to prevent leakage. Teflon sealant tape is provide and should be used on all threaded joints, including the spout.
 8. Check hoses for weak or worn condition before each use, making sure that all connections are secure.

(* Any of the NFPA Codes can be obtained from: National Fire Protection Association, Inc., Batterymarch Park, Quincy MA 02269. Phone (617) 770-3000. Write or call for listing and prices.

9. Periodically inspect pump and system components. Perform routine maintenance as required. Inspect the syphon breaker regularly to ensure proper operation (See Maintenance section).

10. Drain all liquids from the system before servicing.
11. PREVENT SPILLING LIQUID WHEN REMOVING PUMP FROM BARREL:
 - a. Straighten the discharge hose and hold it below the pump discharge. Allow hose to drain into a container.
 - b. Loosen bung adapter clamp (Ref. No. 30, Figure 8).
 - c. Pull pump from bung adapter and allow suction tube to drain back to the barrel. Lay pump flat with handle up. Place container under nozzle. Operate handle until liquid is cleared from pump housing.
 - d. Allow discharge hose to drain. Place the hose nozzle in its hanger. If pump will not be installed in a new barrel, all caustic or corrosive chemicals should be flushed with fresh water internally and externally to prevent personal injury during handling.

▲ WARNING *Any pump used to transfer flammable liquids must be stored in a well ventilated area after use.*

12. Personal Safety:
 - a. Wear safety glasses at all times when working with pump
 - b. Wear a face shield, proper apparel and suitable respiratory equipment when pumping hazardous chemicals.
 - c. Keep work area clean, uncluttered, and properly lighted; replace all unused tools and equipment.
 - d. Keep visitors at a safe distance from the work area.
 - e. Make workshop childproof with padlocks, master switches and by removing starter keys.

▲ WARNING *Failure to follow all general safety information can result in a fatality, personal injury and/or property damage!*
Installation
(All Ref. Nos. correspond to the Replacement Parts List, Figure 9).

1. Screw the bung adapter (Ref. No. 30) into the drum or barrel. Be sure that the gasket (Ref. No. 29) is in place and that the threads are not over-tightened.

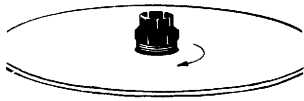

Figure 1

2. Install the bung adapter clamp loosely around the bung adapter.
3. Thread the reducer bushing (Ref. No. 35) and the appropriate length of suction tube (Ref. No. 33) into pump inlet. Use the Teflon sealant tape provided.

NOTE: The suction tube and extension tube supplied are 19½" long. The suction tube has a bevel cut at one end and is threaded at the other end. The extension tubes are threaded at both ends.

A 55 gallon drum requires one extension tube, one coupling and one suction tube, threaded together (See Figure 2). For 275 gallon tanks, thread together two extension tubes, two couplings (one of each is supplied with pump. See Replacement Parts List to order others if needed), and one suction tube.

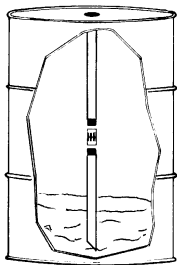

Figure 2

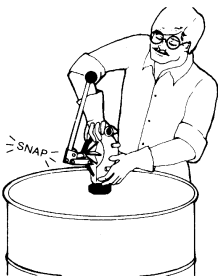

Figure 3

4. Install pump and tubing into bung adapter by firmly pushing straight down. Pump will snap into place (See Figure 3). Tighten the bung adapter clamp. Thread hose assembly (Ref. No. 16) and adapter or spout (Ref. No. 34) into pump housing.
5. The handle position can be changed to either the 12:00 or 6:00 positions.
 - a. Remove hairpin clip (Ref. No. 6) from the clevis pin (Ref. No. 7).
 - b. Remove clevis pin from housing to free links (Ref. No. 8). See Figure 4.

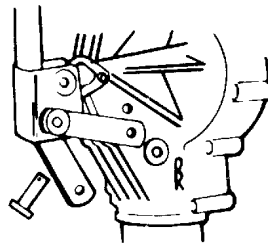

Figure 4

- c. With links clear of housing, rotate handle one-half turn to new position

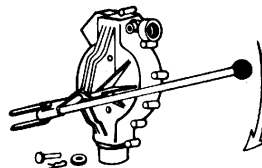

Figure 5

- d. Install clevis pin through the links and the opposite hole in the housing.

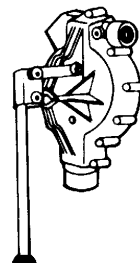

Figure 6

- e. Install hairpin clip through the hole in the clevis pin. Ensure that the flat washer (Ref. No. 5)

is installed between the hairpin clip and the link.

6. A spout (Ref. No. 34) is provided as a standard accessory. The spout is threaded into the 3/4" discharge outlet. (Position spout downward). Wrap the threads with Teflon tape (approx. 2 turns) and screw in hand tight only.

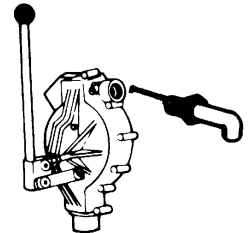

Figure 7

Operation

1. Remove hose from hanger and place nozzle in a container. Operate handle to prime the pump. Six to twelve rapid strokes are required under most conditions for priming. After the pump is primed, it will deliver about one gallon for every five strokes (17 gallons per 100 strokes).

NOTE: A vacuum breaker is built into the pump discharge. This prevents siphoning the drum if the hose drops from its hanger.

NOTE: The barrel is vented by four relief channels molded into the bung adapter. This prevents drawing a vacuum in the barrel.

Maintenance

Important: Periodically inspect the pump, hose assembly and suction tubes for weak or worn conditions. Make certain that all connections and fasteners are tight and secure. Perform routine maintenance as required.

1. To test vacuum breaker, lay loose on ground with nozzle in a suitable container to hold the liquid. Operate the handle until liquid flows from the nozzle. Stop pumping: the hose should drain and the flow should stop. If flow continues without moving the handle, place the nozzle in its hanger to stop the flow. Inspect the vacuum breaker vent for blocking or freezing. Flush the

Repair Parts List

Reference Number	Description	Part Number for Models:		Quantity
		4661-99	4660-99	
1	Pump body	4661-001-00	4660-001-00	1
2	Handle	4660-101-90	4660-101-90	1
3	Grip	4660-104-00	4660-104-00	1
4	Clevis pin, plated 5/16 x 1 1/8"	1766-024-00	1766-024-00	1
5	5/16" Flat washer	1790-003-00	1790-003-00	3
6	Cotter pins, plates	1766-022-00	1766-022-00	3
7	Clevis pins, plated 5/16 x 1 3/8"	1766-025-00	1766-025-00	2
8	Link, plated	4660-105-00	4660-105-00	2
9	Screw, #10 x 3/4", S.S.	*	*	2
10	Retaining plate	4661-050-00	4660-050-00	1
11	Piston rod O-ring, Viton	2186-002-00	2186-002-00	1
12	Vent plug	4661-051-00	4660-051-00	1
13	Vacuum valve, Viton	4660-052-00	4660-052-00	1
14	Nozzle	4661-173-00	4660-073-00	1
15	Hose clamp, S.S.	N/A	N/A	N/A
16	Hose, 8 Ft.	N/A	N/A	N/A
17	Gasket, cork/nitrile	4660-300-00	4660-300-00	1
18	Front cover	4661-020-00	4660-020-00	1
19	Hex hd. screw, 1/4-20 x 2" S.S.	*	*	12
20	Hose adapter	4661-172-00	4660-172-00	1
21	Hex nut, 1/4-20 S.S.	*	*	12
22	Valve assembly, small	4661-070-99	4660-070-99	2
23	Valve assembly, large	4661-071-99	4660-071-99	2
25	Piston assembly, S.S. with Viton O-ring and Teflon ring	4661-012-99	4660-012-99	1
26	Piston O-ring, Viton	2186-003-00	2186-003-00	1
27	Piston ring, Teflon	4660-304-00	4660-304-00	1
28	Bung adapter clamp, S.S.	4660-184-00	4660-184-00	1
29	Bung adapter gasket, cork/nitrile	4660-301-00	4660-301-00	1
30	Bung adapter assembly	4661-174-99	4660-174-99	1
▲31	†Suction tube extension	4661-175-00	4660-175-00	1
▲32	Coupling	4661-177-00	4660-177-00	1
33	§Suction tube	4661-176-00	4660-176-00	1
34	Spout, 3/4" NPT	4661-179-00	4660-179-00	1
35	Reducer bushing	4661-181-00	4660-181-00	1
◇	Teflon tape	1696-094-00	1696-094-00	1

(*) Standard hardware item, available locally.

(†) Both sides threaded.

(§) One side threaded.

(▲) Pump reaches depth of 55 gallon drum with pieces provided. To reach depth of 275 gallon tank requires an addition of one (1) each of Ref. Nos. 34 and 35 (these extra parts are not supplied).

(◇) Not shown.

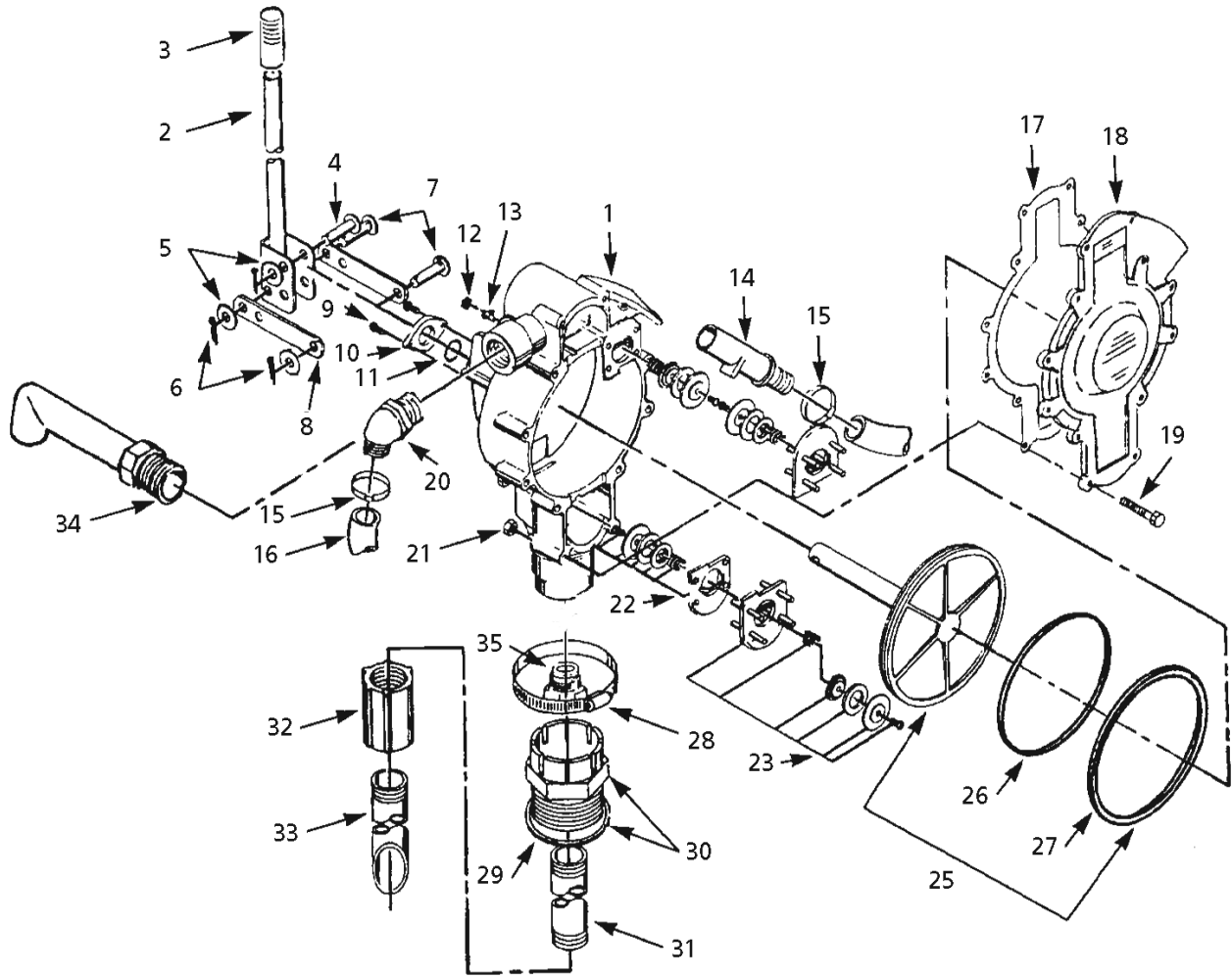

vent with fresh water if pumping chemicals, or with cleaning product if pumping petroleum products.

IN ORDER TO INSPECT INTERNAL PARTS, THE PUMP MUST BE DISASSEMBLED AS FOLLOWS:

1. Remove hose assembly and suction tubes from the pump housing.
2. Remove hex nuts (Ref. No. 21) and screws (Ref. No. 19) from the pump housing. Remove cover plate (Ref. No. 18) and gasket (Ref. No. 17), being careful not to damage the gasket.
3. Remove large and small valve assemblies (Ref. Nos. 11 and 23) and inspect for broken or weak springs or damaged or clogged valves.
4. Remove cotter pin (Ref. No. 6) from 1" clevis pin (Ref. No. 3) which holds handle (Ref. No. 2) to the piston rod. Remove cotter pin clip, flat washer and clevis pin (Ref. Nos. 6, 4 and 7) from links (Ref. No. 8). Remove pin from piston rod and set handle aside. Slide piston assembly (Ref. No. 25) from the housing (Ref. No. 1)
5. Inspect Teflon piston (Ref. No. 27) in piston groove. It must extend 1/32" above the edge of the piston to seal properly. If the ring has worn flush with the piston edge,

then the Teflon piston ring must be replaced. When replacing the Teflon piston ring, always replace the Viton O-ring (Ref. No. 26) because extended compression reduces its ability to seal.

6. Inspect piston bore in housing (Ref. No. 1) for wear. Any gouging or scraping indicates the liquid being pumped contains abrasives. Replace the housing, Teflon piston ring and Viton O-ring (Ref. Nos. 1, 26 and 27) if the surfaces are gouged or worn.
7. Remove the two screws (Ref. No. 9) which hold retaining plate (Ref. No. 10) to the housing. Remove plate to expose piston rod O-ring (Ref. No. 1). Replace O-ring if worn or cut.

IN ORDER TO REASSEMBLE THE PUMP, PROCEED AS FOLLOWS:

1. Install piston rod O-ring (Ref. No. 11). Install retaining plate (Ref. No. 10) with the groove facing away from the pump housing. Ensure that the Viton O-ring is inserted in the piston ring groove first and then the Teflon piston ring. Slide piston rod into housing. The Teflon piston ring may catch on the edge of the housing. To help seat the ring, turn piston slowly while pushing ring into groove with fingers. **DO NOT FORCE THE PISTON!**

2. Install clevis pin (Ref. No. 3) through the piston rod and handle.
3. Install the two small valve assemblies (Ref. No. 22) in the housing first and then the two large valve assemblies (Ref. No. 23). There is a small tab molded into the valve seats which fits a guide channel in the housing. This prevents installing the valve seats backwards. If these tabs are broken, please note the (lower) suction valve seats should have their springs facing each other and that the (upper) discharge valve seats should have their springs facing away from each other, when installed.
4. Inspect cover plate gasket (Ref. No. 17) for damage.
5. Lay cover plate and gasket assembly on the housing and install screws (Ref. No. 19) and hex nuts (Ref. No. 21). Tighten the screws and nuts firmly enough to compress the gasket. **DO NOT OVER TIGHTEN!**
6. Install the hose and suction tubes as required. Refer to Figure 3.